

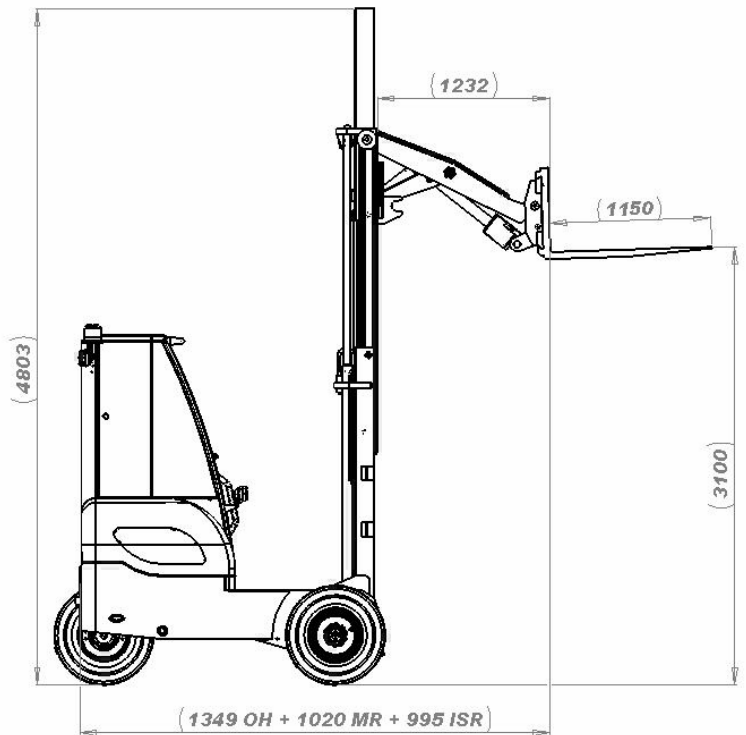

The only **true** double stack **one side offload** truck mounted forklift – setting new standards.

- ✓ Patent protected **One Side Offload** with normal forks, – Standard
- ✓ Rubber mounted operators cab – Standard
- ✓ Operator sits inside chassis envelope - Standard
- ✓ Exceptional operator visibility - Standard
- ✓ Autophoretic PVDC undercoat – Standard
- ✓ Top coat paint in your colours - Standard
- ✓ 2 Year warranty – Standard
- ✓ Independent tilt/side shift fork carriage – Standard
- ✓ Fits most makes of mounting kit – Standard
- ✓ Full 180° lock to lock on rear wheel – Standard
- ✓ Semi-auto multi-directional change – Standard
- ✓ Multi-directional rams closed in transit – Standard
- ✓ Recessed LED 24v road lights - Standard
- ✓ **Designed & Built in Britain** – Compulsory!
- ✓ Direct factory sales and service – Standard
- ✓ Service Response UK cover -Standard

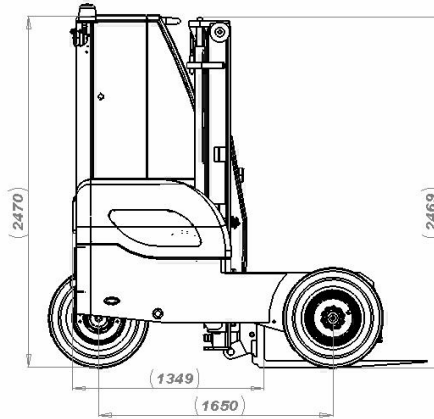

**Capacity:** 2500kgs @ 600mm load centre

**Lift Height:** 3100mm

**Reach:** Class 3 Moving Mast with Integrated **Second Reach** and standard 1150mm profile/length forks

**Engine:** 35Kw (49hp) Yanmar 4TNV88 2200cc Naturally Aspirated Direct Injection Industrial Diesel Engine. Direct coupled hydrostatic drive pump. Direct coupled gear pump feeding steering and auxiliary circuits.

**Tyres:** 27 x 10 or 280/60-15 Front and Rear.

**Weight:** 2680kgs (wet) with 450mm CoG.

**Overhang:** 1349mm

**Gradeability:** 30%

